

Digital Circuits

Digital Electronics

Wolfgang Neff

Digital Circuits (1)

- Analog and Digital
 - Analog Circuits
 - Any voltage level allowed
 - Digital Circuits
 - Two voltage levels allowed
 - + and –
 - 1 and 0
 - H and L

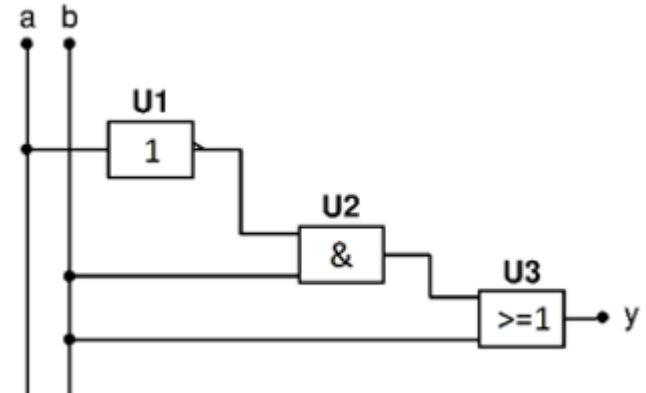
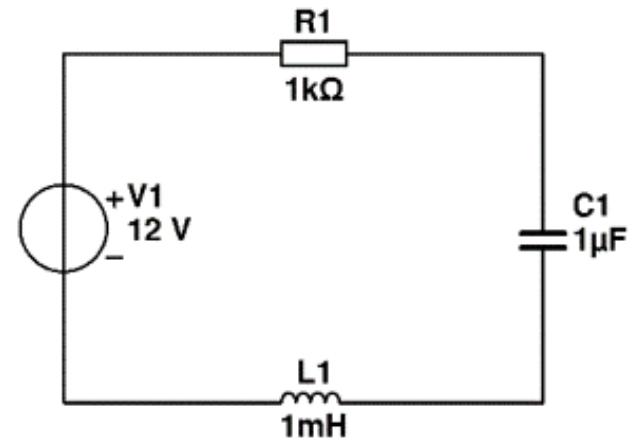

Digital Circuits (2)

- Basic Concept
 - Based on Boolean algebra
 - 0 → Low voltage
 - 1 → High voltage
 - Operator → Symbol
 - Function → Circuit
 - Terms
 - Logical functions → Switching function
 - Truth table → Switching table

Digital Circuits (3)

- Basic Concept (continued)
 - Truth function ...
 - $\phi(a,b) = (\neg a \wedge b) \vee b$
 - ... represented graphically

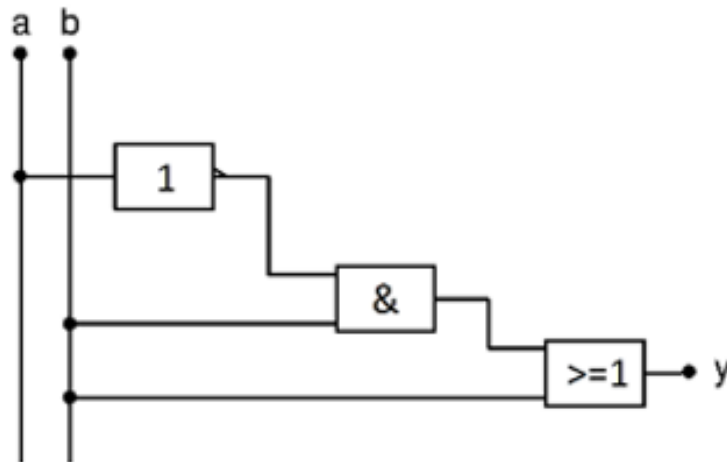

Digital Circuits (4)

- Graphic Symbols

- Buffer

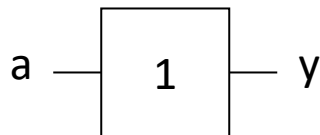

European Style
(IEC 60617-12)

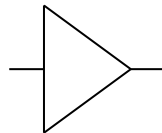

American Style
(IEEE 315-1975)

a	y=a
0	0
1	1

- Negation (NOT, \neg)

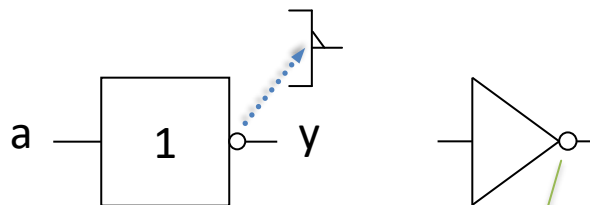

Inversion Circle

a	y= \neg a
0	1
1	0

Digital Circuits (5)

- Graphic Symbols (continued)

- Disjunction (OR, \vee)

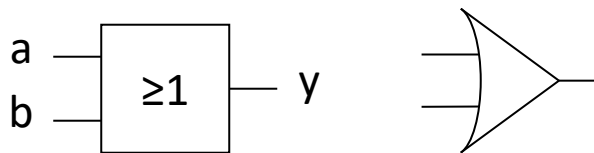

a	b	$y=a\vee b$
0	0	0
0	1	1
1	0	1
1	1	1

- Conjunction (AND, \wedge)

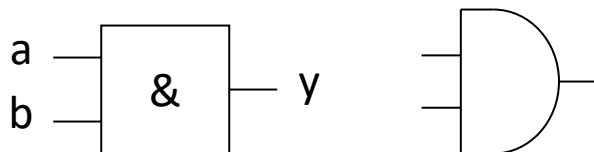

a	b	$y=a\wedge b$
0	0	0
0	1	0
1	0	0
1	1	1

Digital Circuits (6)

- Graphic Symbols (continued)

– NOR (\downarrow)

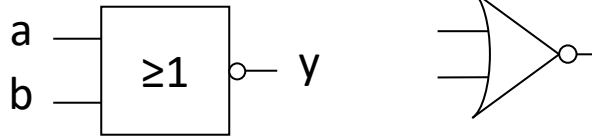

a	b	$y=a\downarrow b$
0	0	1
0	1	0
1	0	0
1	1	0

– NAND (\uparrow)

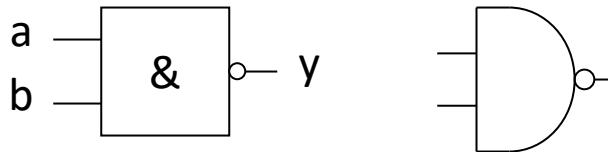

a	b	$y=a b$
0	0	1
0	1	1
1	0	1
1	1	0

Digital Circuits (7)

- Graphic Symbols (finished)

- XOR (\oplus)

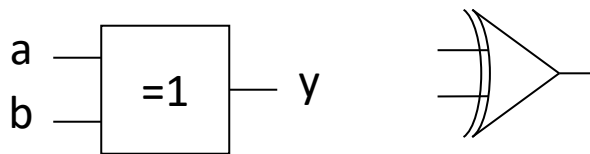

a	b	$y=a\oplus b$
0	0	0
0	1	1
1	0	1
1	1	0

- Compound Gates

- AND-Gate

- $y = a_0 \wedge a_1 \wedge a_2 \dots$

$$(a_0, a_1, \dots) \mapsto \begin{cases} 1 & \text{if each } a_i = 1 \\ 0 & \text{else} \end{cases}$$

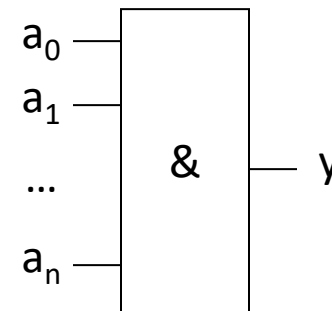

Digital Circuits (8)

- Compound Gates (continued)

- OR-Gate

- $y = a_0 \vee a_1 \vee a_2 \dots$

$$(a_0, a_1, \dots) \mapsto \begin{cases} 0 & \text{if each } a_i = 0 \\ 1 & \text{else} \end{cases}$$

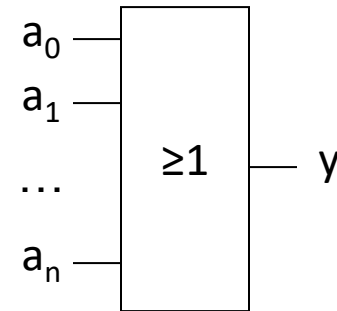

- Composition

- Example

- $\neg((a_0 \wedge a_1) \vee (\neg a_2 \wedge a_3))$

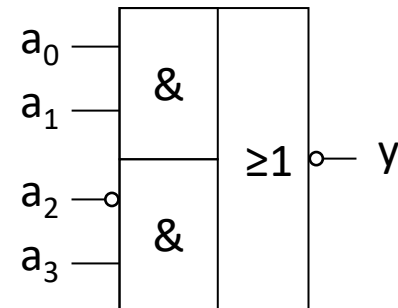

Digital Circuits (9)

- Building Blocks

$$- y = \neg a \wedge b$$

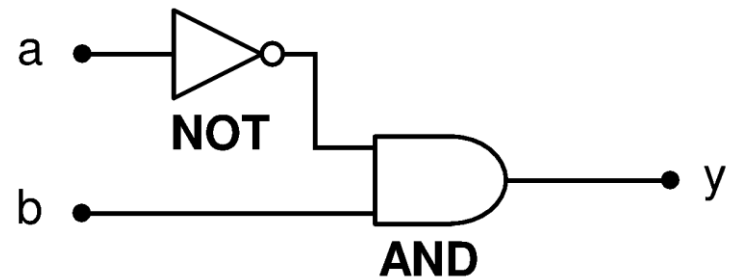
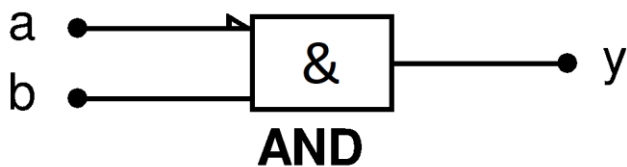
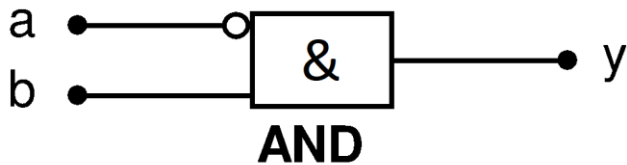

Digital Circuits (10)

- Building Blocks (continued)

$$- y = \neg(a \wedge b)$$

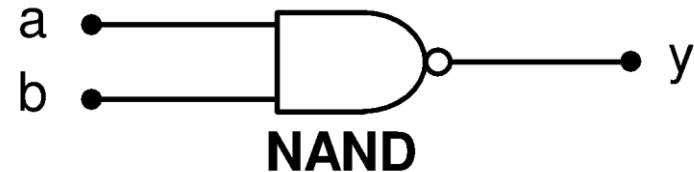
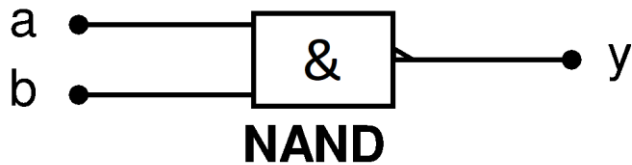
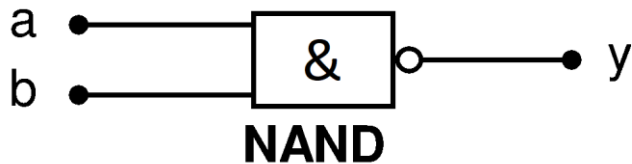

Digital Circuits (11)

- Building Blocks *(continued)*

– $y = (a \wedge b) \vee c$

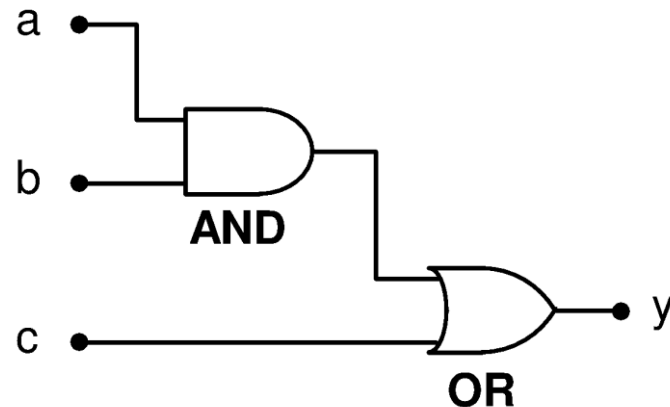
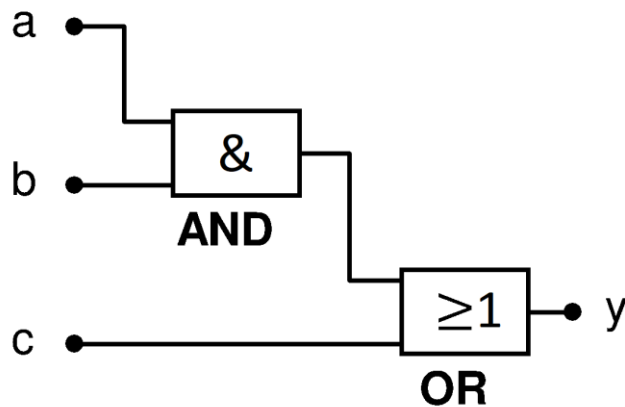

Digital Circuits (12)

- Building Blocks *(finished)*
 - $y = a \wedge (b \vee c)$

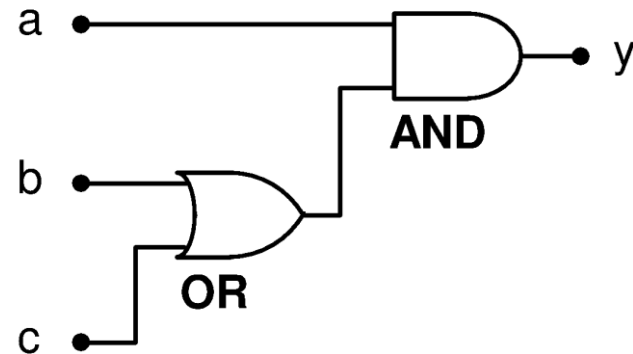
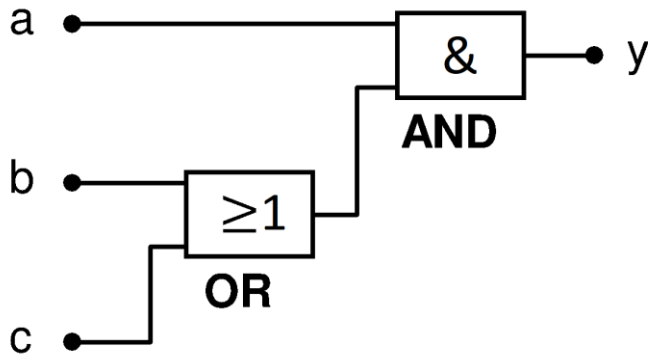

Digital Circuits (13)

- Example: Building Blocks in Action
 - $y = (a \wedge \neg b) \vee \neg(c \wedge a) \vee c$

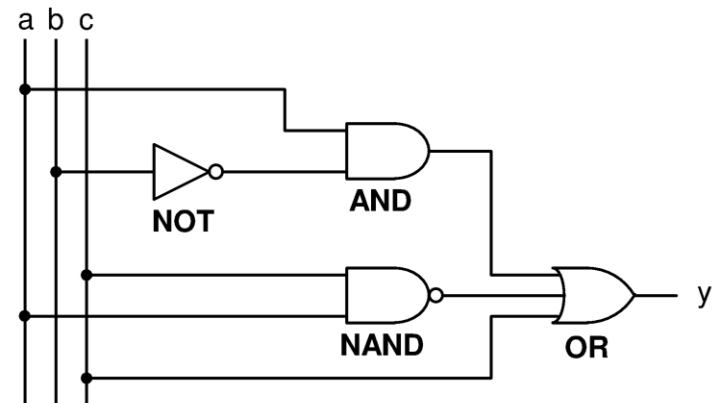
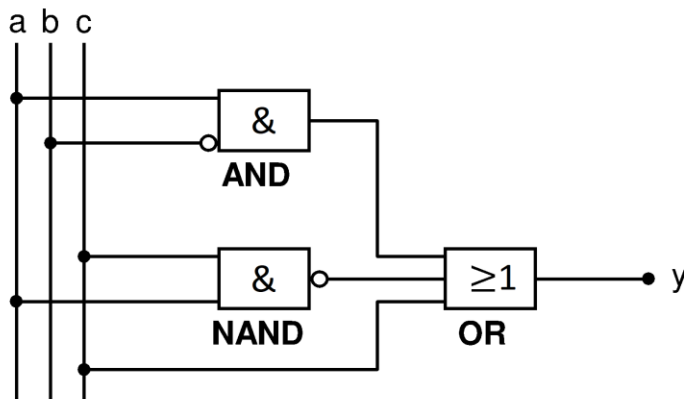

Digital Circuits (14)

- From Circuit to Function
 - Tip: Annotate the lines

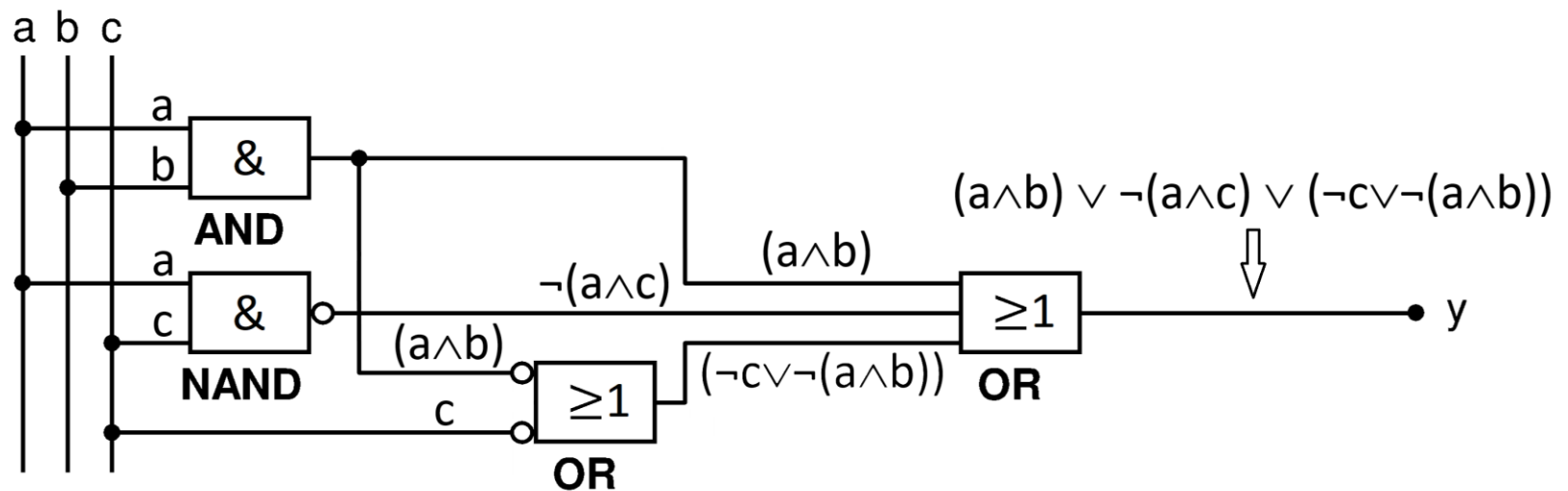

$$y = (a \wedge b) \vee \neg(a \wedge c) \vee (\neg c \vee \neg(a \wedge b))$$