

Transistors

Digital Electronics

by Wolfgang Neff

Transistors (1)

- Bipolar Junction Transistor

- Abbreviation: BJT
- Two p-n junctions
- Two different types
 - NPN transistor
 - PNP transistor

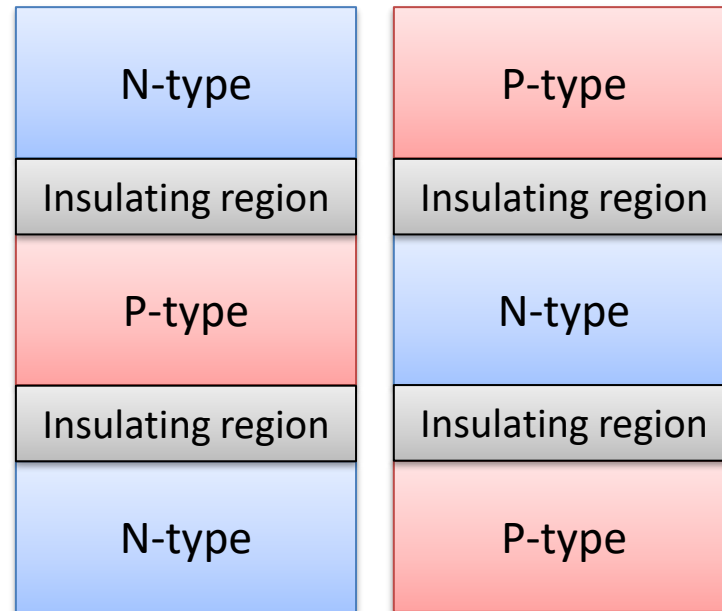

Transistors (2)

- Bipolar junction transistor (continued)

- Applying Voltages

- Does not help
 - Whatever polarity
 - One junction blocks anyway

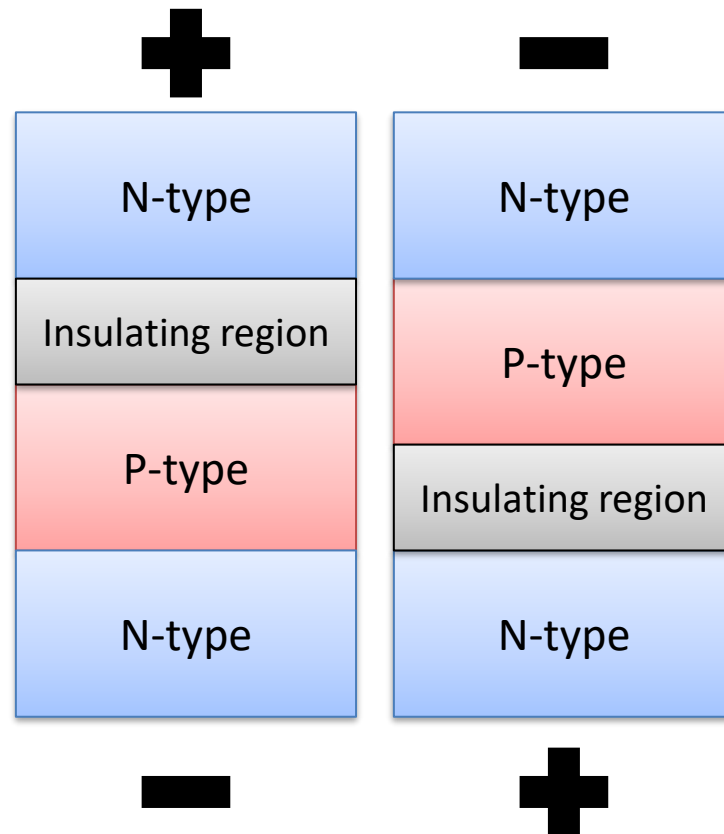

Transistors (3)

- Bipolar junction transistor (continued)

- Third lead

- Insulating region vanishes
- Controls the flow of electric current
- Acts like a switch

WOW!

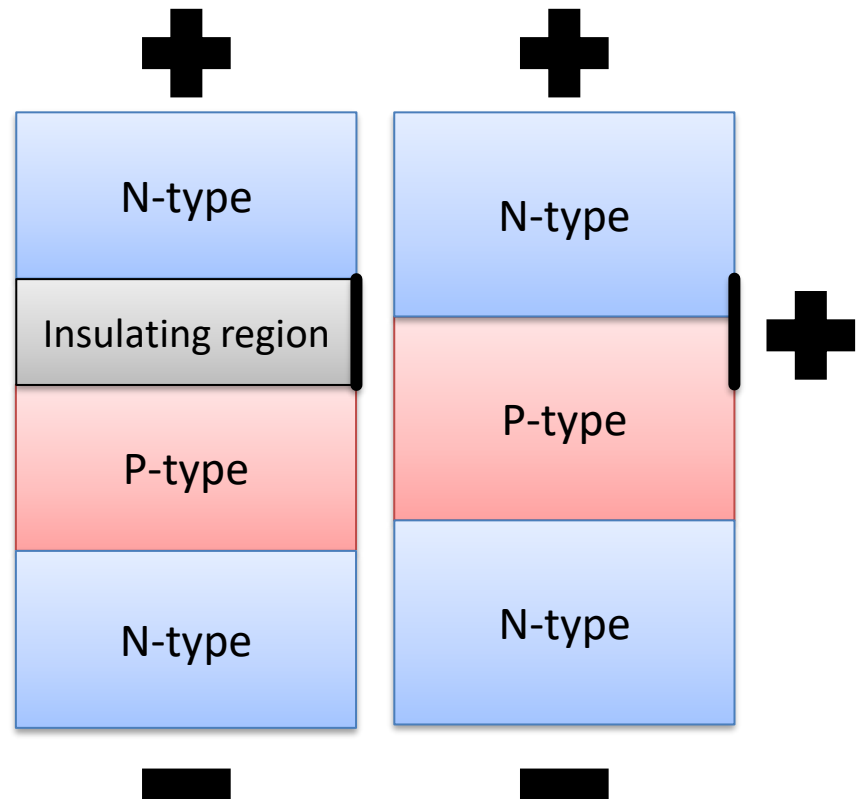

Transistors (4)

- Bipolar junction transistor (finished)
 - Two types
 - NPN transistor
 - PNP transistor
 - Three leads
 - Base
 - Collector
 - Emitter

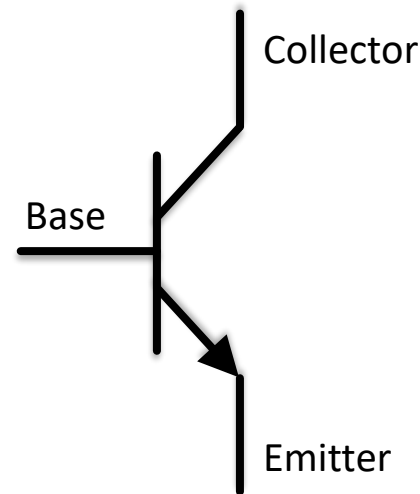

NPN transistor

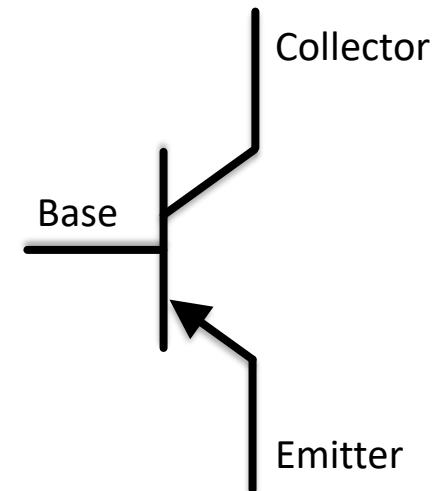

PNP transistor

Transistors (5)

- NPN Transistor

- Load current flows from collector to emitter ...

- ... if base current flows **into** the base

- A positive voltage between base and emitter is necessary

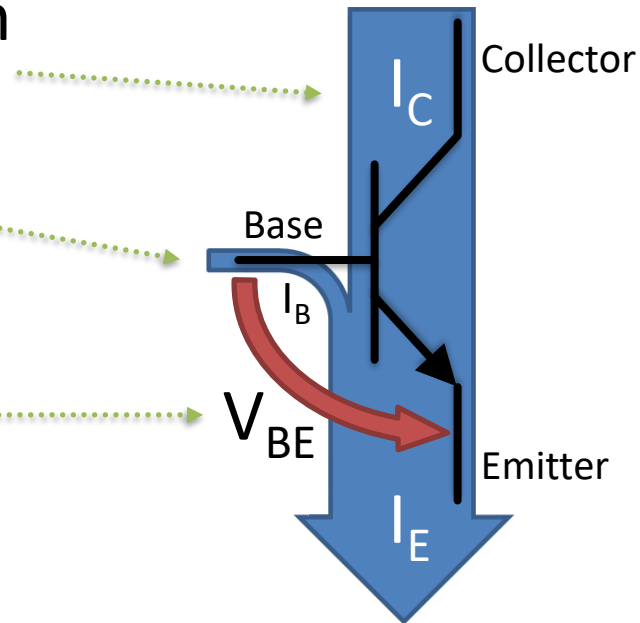

Transistors (6)

- NPN Transistor (continued)

- Transistor as switch

- Load at collector
- Controlled by base
 - On if $V_{BE} > 0$
 - Off if $V_{BE} = 0$
- Active high
 - On if base is high
 - Off if base is low

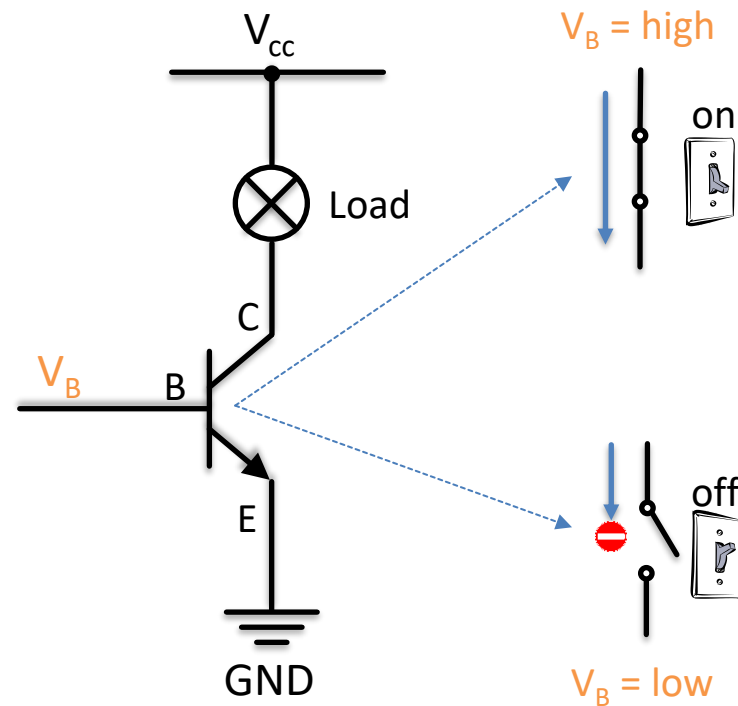

Transistors (7)

- NPN Transistor (finished)
 - Example: BC547
 - Maximum collector current
 - $I_C = 100 \text{ mA}$
 - Base saturation voltage
 - $V_{BE} = 0.7 \text{ V}$
 - DC current gain
 - $h_{FE} = \frac{I_C}{I_B}$
 - $h_{FE} \approx 250$

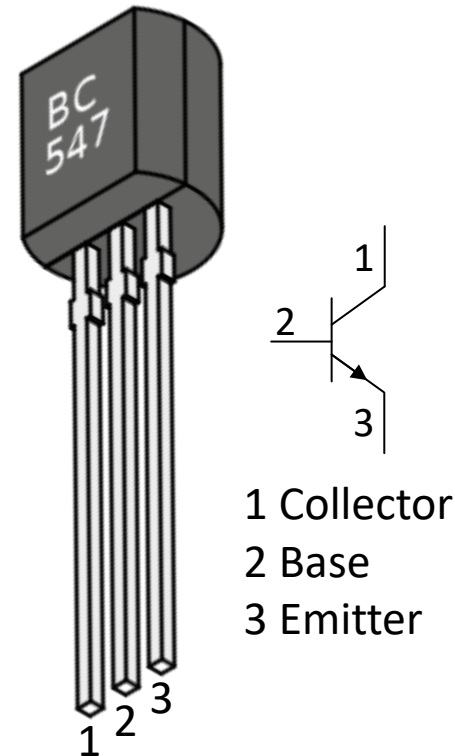

Transistors (8)

- PNP Transistor

- Load current flows from emitter to collector ...
- ... if base current flows **out** of the base
- A negative voltage between base and emitter is necessary

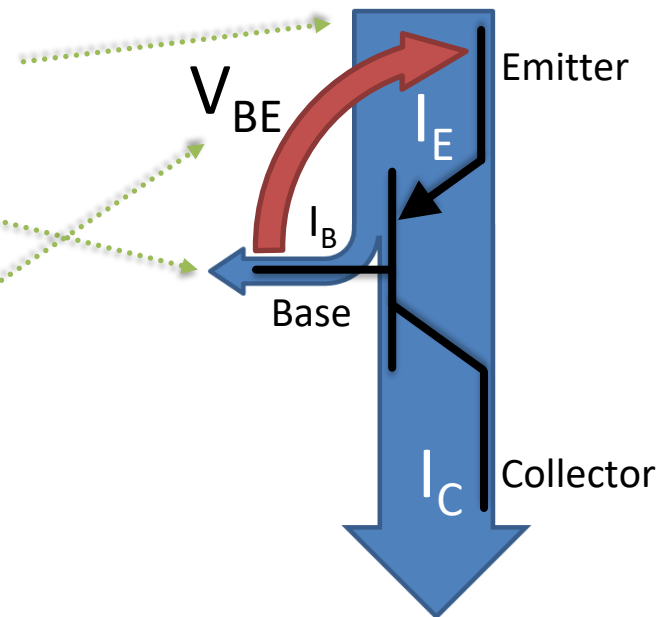

Transistors (9)

- PNP Transistor (continued)

- Transistor as switch

- Load at collector
- Controlled by base
 - On if $V_{BE} < V_{CC}$
 - Off if $V_{BE} = V_{CC}$
- Active low
 - On if base is low
 - Off if base is high

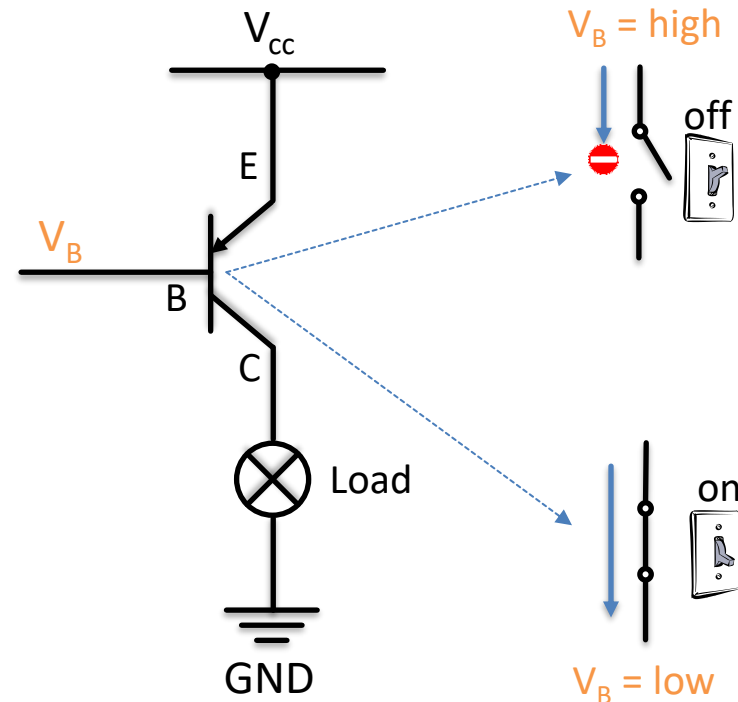

Transistors (10)

- PNP Transistor (finished)
 - Example: BC557
 - Maximum collector current
 - $I_C = -100 \text{ mA}$
 - Base saturation voltage
 - $V_{BE} = -0.7 \text{ V}$
 - DC current gain
 - $h_{FE} = \frac{I_C}{I_B}$
 - $h_{FE} \approx 250$

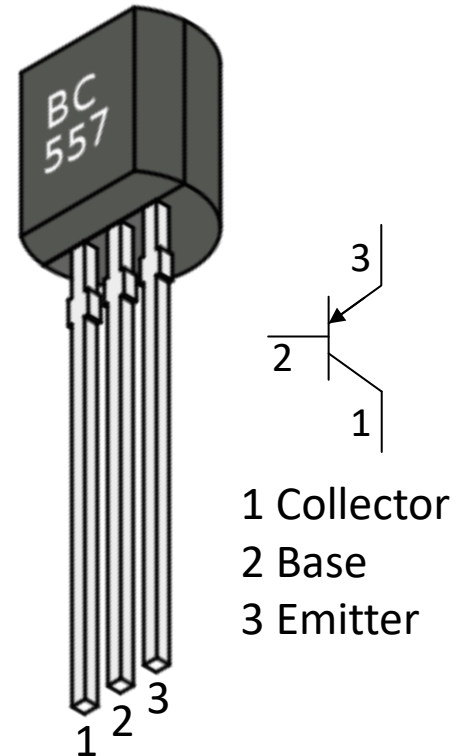

Transistors (11)

- MOSFET
 - Metal-Oxide-Semiconductor
 - Field-Effect Transistor
 - Controlled by voltage
 - No current necessary
 - Used in Chips
 - Integrated Circuits

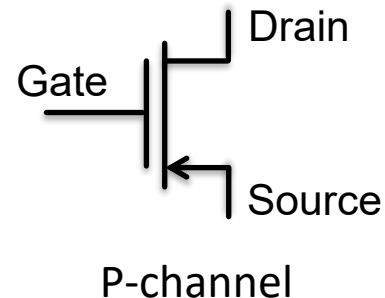
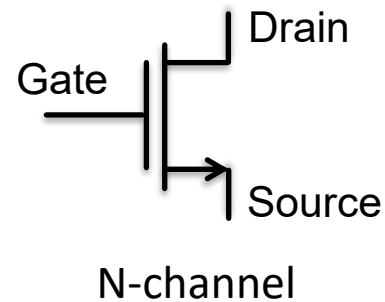
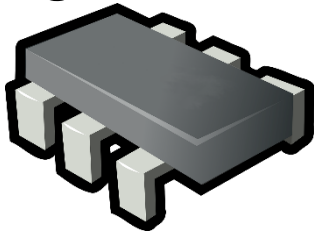

Transistors (12)

- BJT versus MOSFET

- NPN / N-Channel

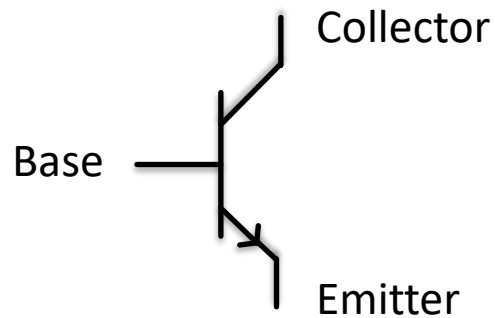

BJT

- PNP / P-Channel

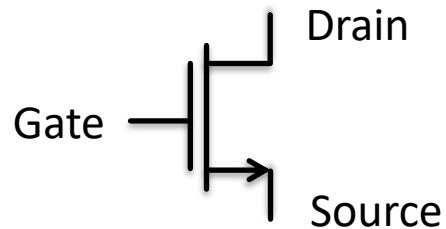
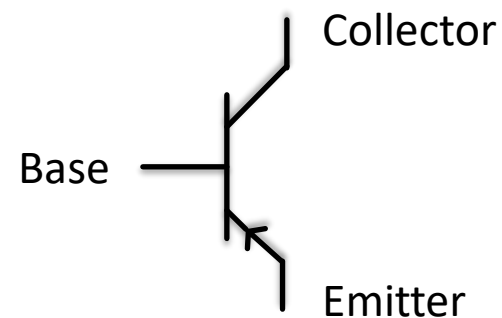

MOSFET

