

# Voltage Divider

Electrical Engineering

Wolfgang Neff

# Voltage Divider (1)

- Mode of Operation

- Reduce voltage with the aid of resistors
- Two resistors in series
- Two modes
  - Unloaded voltage divider
    - $I_L = 0 \text{ A}$  ( $I_L \leq 0.1 \cdot I_1$ )
    - There is no load on  $V_{\text{out}}$
  - Loaded voltage divider
    - $I_L > 0 \text{ A}$  ( $I_L > 0.1 \cdot I_1$ )
    - There is a load on  $V_{\text{out}}$

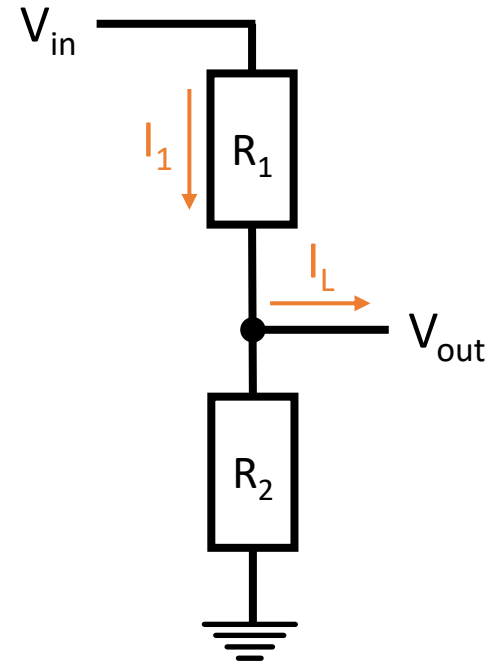

# Voltage Divider (2)

- Unloaded voltage divider

- Given values

- $R_1, R_2, V_{in}$

- Required values

- $V_{out}, I_V, P_{tot}$

- Relations

- $I_L = 0 A$
    - $V_{out} = V_2$
    - $I_V = I_1 = I_2$
    - $R_{tot} = R_1 + R_2$
    - $P_{tot} = V_{in} \cdot I_V$

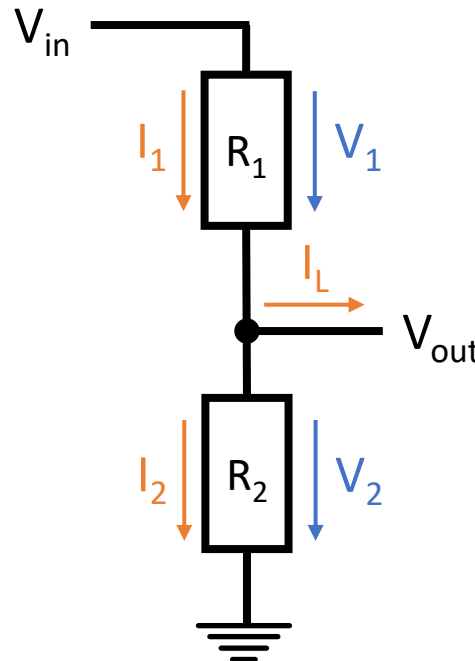

$V_{in}$ : Input Voltage

$V_{out}$ : Output Voltage

$I_L$ : Load Current

$I_V$ : Vertical Current

$R_{tot}$ : Total Resistance

$P_{tot}$ : Total Power Loss

# Voltage Divider (3)

- Unloaded voltage divider (continued)

- Relations

- $I_2 = \frac{V_2}{R_2}$

- $\frac{V_2}{V_{in}} = \frac{R_2}{R_{tot}}$

- Formulas

- $V_{out} = \frac{R_2}{R_1 + R_2} \cdot V_{in}$

- $I_V = \frac{V_{out}}{R_2}$

- $P_{tot} = \frac{V_{in} \cdot V_{out}}{R_2}$

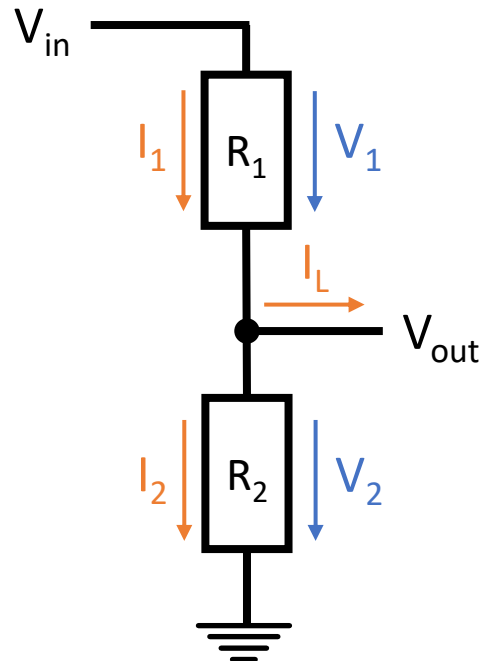

# Voltage Divider (4)

- Unloaded voltage divider (example)

- Given values

- $V_{in} = 5 \text{ V}$
- $R_1 = 100 \Omega$
- $R_2 = 120 \Omega$

- Calculation

- $$V_{out} = \frac{R_2}{R_1 + R_2} \cdot V_{in}$$
$$= \frac{120 \Omega}{100 \Omega + 120 \Omega} \cdot 5 \text{ V}$$
$$= 2.73 \text{ V}$$

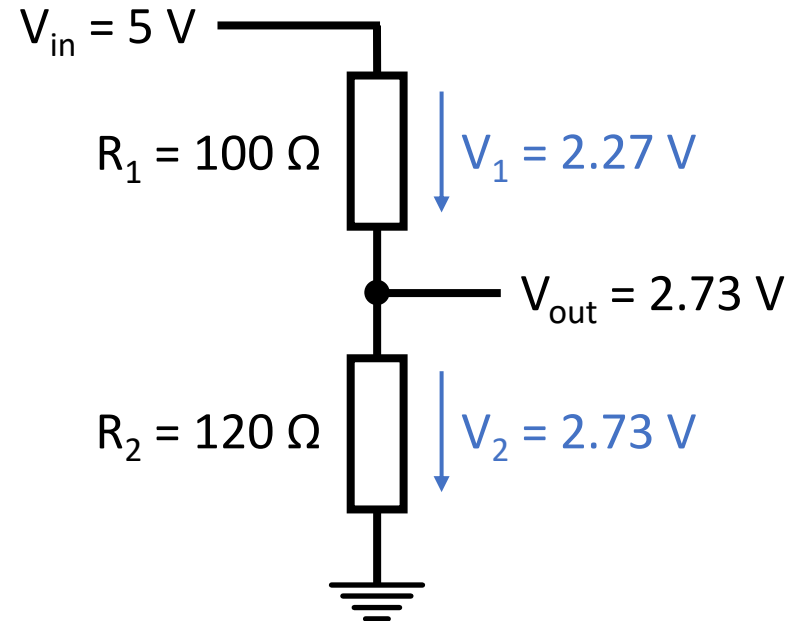

# Voltage Divider (5)

- Unloaded voltage divider (example continued)

- Calculation

- $$I_V = \frac{V_{out}}{R_2}$$
$$= \frac{2.73 V}{120 \Omega}$$
$$= 23 mA$$

- $$P_{tot} = \frac{V_{in} \cdot V_{out}}{R_2}$$
$$= \frac{5 V \cdot 2.73 V}{120 \Omega}$$
$$= 114 mW$$

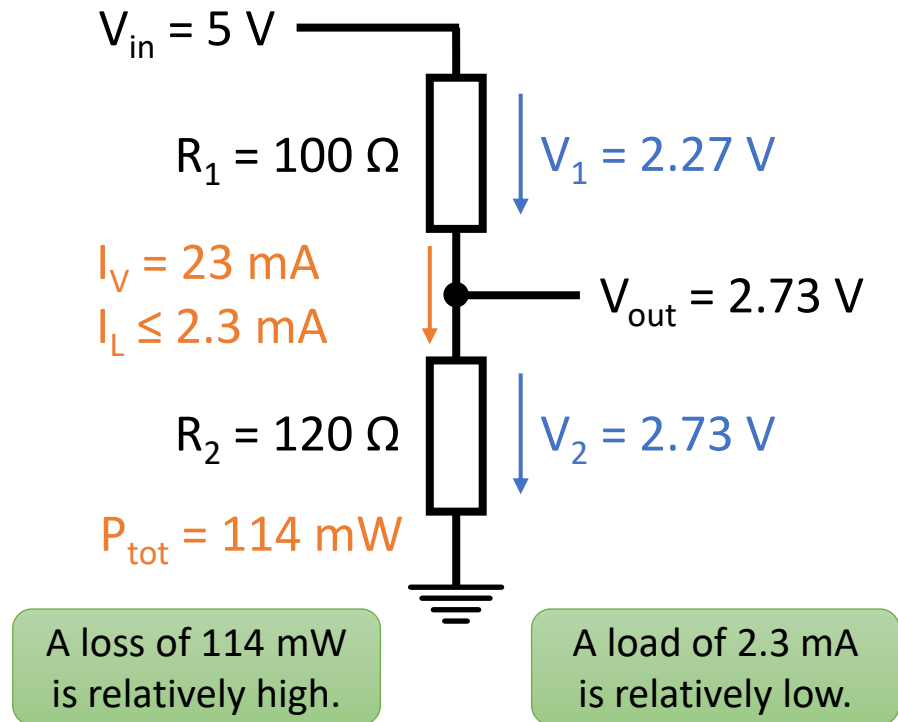

# Voltage Divider (6)

- Voltage Divider with Amplifier
  - Loaded voltage divider are difficult to handle
    - Current load may be unknown
    - Current load may vary
  - An amplifier can eliminate the load current

