

Switches

Electrical Engineering

by Wolfgang Neff

Switches (1)

- Electric Control Component

- In general

- Circuit breaker
 - Opens or closes an electric circuit

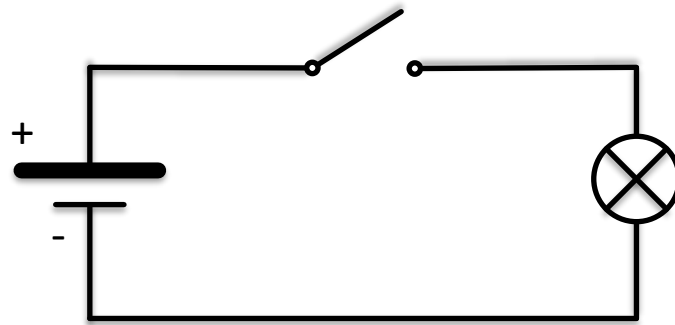

- In particular

- Switches a device on or off

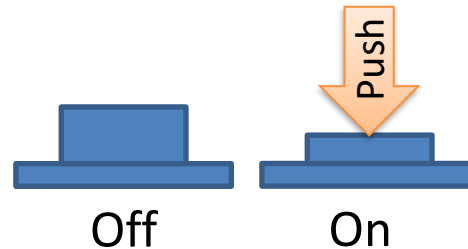

Switches (2)

- Push Button
 - On/off when pressed
 - Off/on when released
- Switch
 - Button with locking
 - On/off when pressed
 - Off/on when pressed again

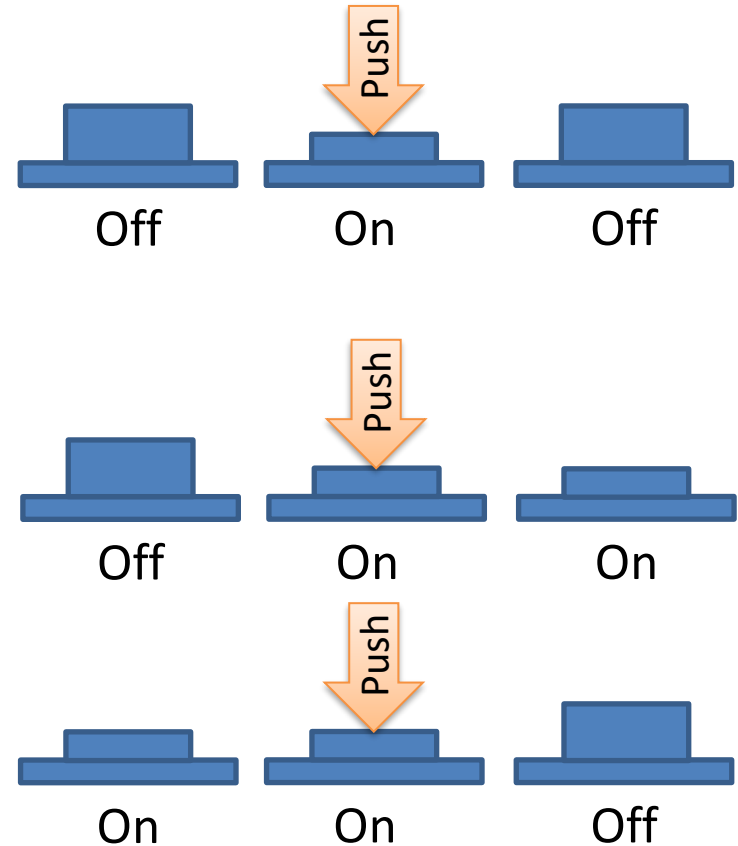

Switches (3)

- Implementations

- Single pole, single throw (SPST)



Circuit breaker

- Single pole, double throw (SPDT)

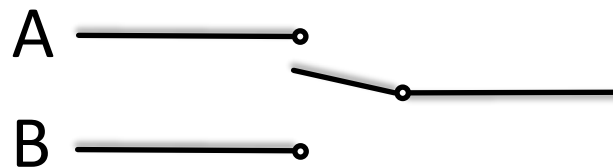

Line selector

Switches (4)

- Implementations (finished)

- “a” Contact

- Closes the circuit if pressed



- “b” Contact

- Opens the circuit if pressed





Switches (5)

- Undefined Voltage Levels
 - SPST can produce undefined voltage levels



– This is a problem for digital circuits

- High → 1 
- Low → 0

- Undefined → ? 

Switches (6)

- Pull-down Resistors
 - For active-high switches with digital output

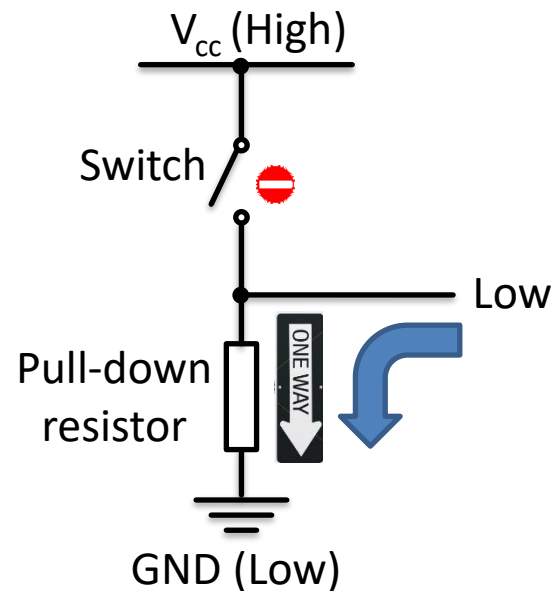
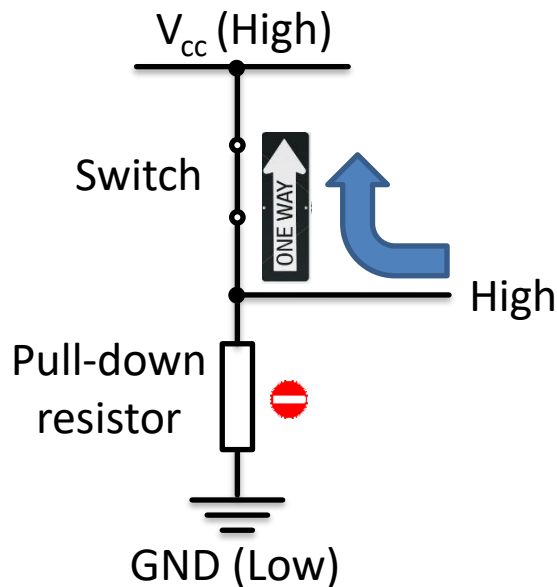

Switches (7)

- Pull-up Resistors
 - For active-low switches with digital output

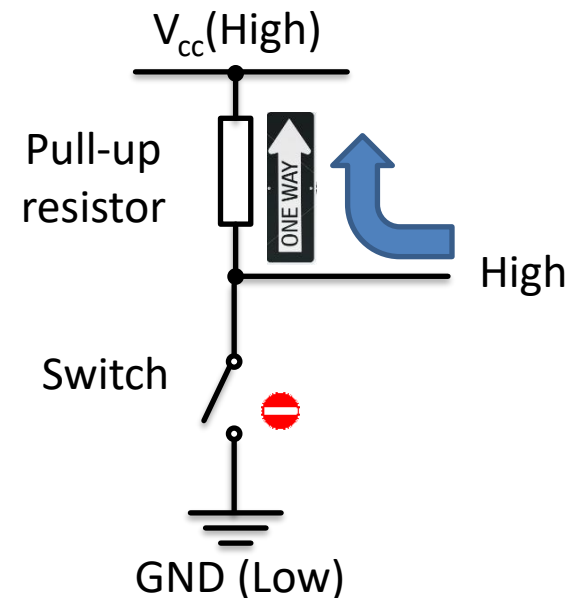
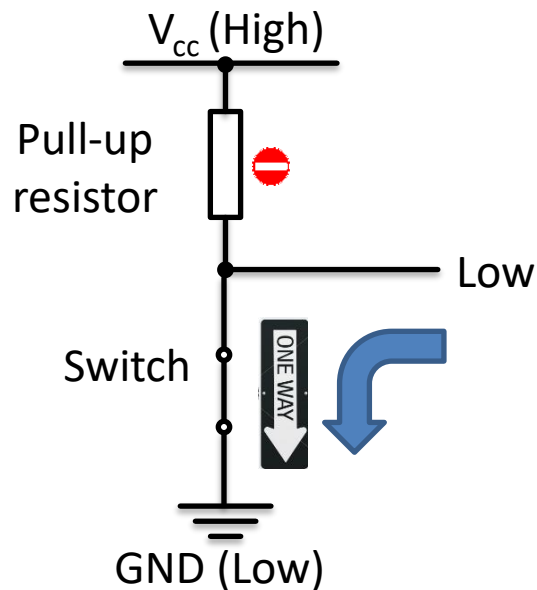

Switches (8)

- Contact Bounce
 - Mechanical switches bounce

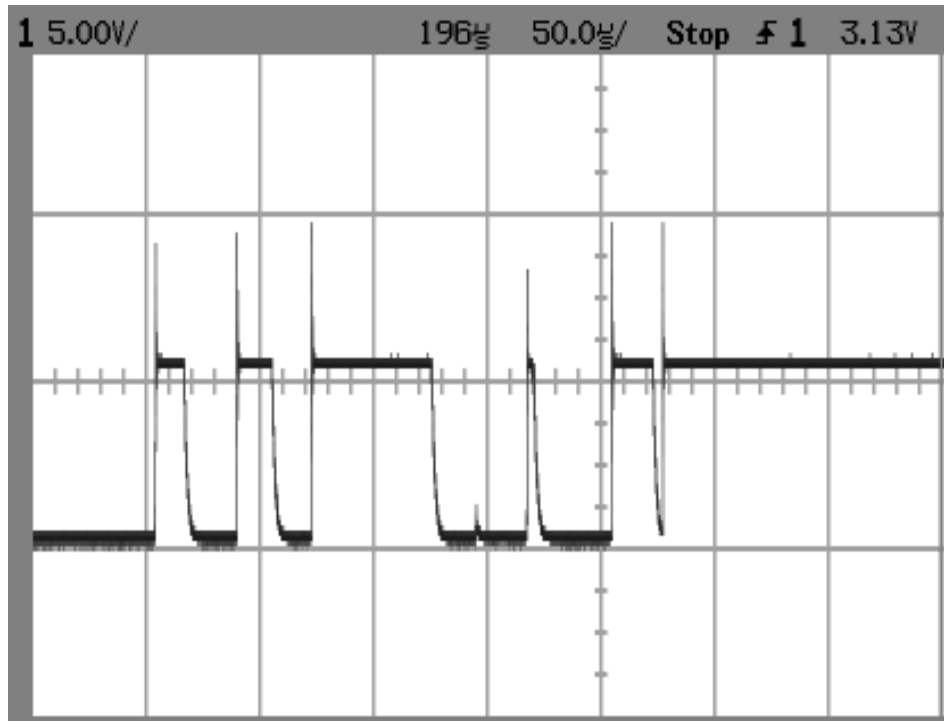

Switches (9)

- Contact Bounce (continued)

- Is the button pressed?

- Yes, it is
- Without doubt

- How many times?

- 4, 5 or 6? 🤪
- Debounce required
 - By hardware
 - By software

